

### MPT-90

#### PAN & TILT POSITIONERS



The MPT Positioner Series leverages the strength and reliability of Quickset legacy products and is improved with an enhanced electronics package offering new advantages to mission critical applications..

MPT Positioners are equipped with an integrated Health and Usage Monitoring System (HUMS). This provides intelligence to users regarding the condition of payloads, allowing for preventative maintenance to extend the life of critical equipment. An embedded web server enables easy discovery and control of all positioners and integrated components on a network thereby eliminating the need for 3rd party software. Expanded velocity control offers the MPT finer resolution of speed and acceleration control, ultimately improving tracking and scaling applications. Users will enjoy the capacity of multiple configurable communication ports for convenient payload integration and communication.

#### KEY FEATURES

##### Control and Configurability

- Embedded web server
- Serial or Serial over IP control up to 99Hz
- Health and usage monitoring
- HD-SDI slip ring models available
- Continuous Rotation available
- Multiple payload communication ports:  
4 configurable serial, 2 TTL and 1 IP port
- 10-bit linear response velocity control
- Standardized connectors
- GPS capability

##### Robust and reliable mechanical design

- Payload capacity up to 100 pounds
- Provides up to 90 foot pounds of elevation torque
- Versatile platform design for ease of customization
- Tabletop design accommodates a wide variety of payloads



# MPT-90

## SPECIFICATIONS

Payload Capacity	100 lb
Payload Rated Load Torque (Elevation)	90 lb-ft (122 N-m)
Positioner Power Consumption	
Max (simultaneous P&T move)	<5.0 A peak, <4.0 A continuous at 24 VDC
Standby (Idle, without heater)	650 mA.
Heater Power (switchable)	100 W
Operating Voltage Range	24 to 28 VDC Nominal (28 to 32 VDC via jumper setting)
Azimuth - Pan	
Range of Travel	Continuous, 435° models available
Speed (@ rated load, nominal voltage)	0.005°/s to 25°/s
Elevation - Tilt	
Range of Travel	180° (± 90° from horizon)
Speed	0.005°/s to 8°/s (90 lb-ft load)
Minimum Incremental Move (Az and/or El)	0.01°
Rotation Limits	
Software Adjustable Limits	Individually adjustable azimuth and elevation (all models)
Mechanically Adjustable Switches	Individually adjustable azimuth & elevation (435° model), Adjustable elevation (continuous rotation models)
Position Feedback	
9000 Line Encoder	Azimuth and Elevation
Resolution	0.01°
Position Repeatability	0.05°
Environmental	IP67
Operating Temperature	
without heater	-15° to 55°C (5° to 131°F), 100% RH
with internal heater	-32° to 55°C (-25.6° to 131°F), 100% RH
Storage Temperature	-40° to 70°C (104° to 158°F)
Construction	Cast Aluminum Housing, Stainless Steel Hardware
Drive System	1.8° stepper motors, Hardened Steel Worm Drive Geartrain
Exterior Finish	Powder Coat White, special finishes available
Weight	HD-SDI model: 74 lb Standard model: 71 lb
Dimensions	HD-SDI model: 19.59 in H x 18.07 in W x 9.57 in D (498 x 459 x 243 mm) Standard model: 16.42 in H x 18.07 in W x 9.57 in H (417 x 459 x 243 mm)
Command and Control	Integral Web Server
Protocol	Quickset PTZ Protocol*, Pelco D (Limited)
Resolution of Velocity Commands	10-bit, linear response
Power Outputs to Payload	
24 VDC - user on/off switchable	5 Amp Max.**
12 VDC - user on/off switchable	5 Amp Max.**
5 VDC - user on/off switchable	4.8 Amp Max.**
Health Monitoring w/Real Time Clock	
Power On and Run Time Monitoring	Included
Voltage Monitoring	Input and User 24 V, 12 V & 5 V Outputs
Current Monitoring	User 24 V, 12 V & 5 V Outputs
Communication Interfaces to Payload	
Serial (RS232, RS422, RS485 configurable)	4
TTL	2
IP	1
Connector to Positioner	53 conductor D38999
Connector to Payload	53 conductor D38999 (x2)
Duty Cycle	This positioner is designed for periodic movement. For applications requiring constant motion, please contact our team for solutions tailored to your use case and environment.

\* backward compatible with PTCR-96

\*\* total payload current limited to 8A, power may be increased with higher supply voltage.  
Specifications subject to change.

## DIMENSIONS

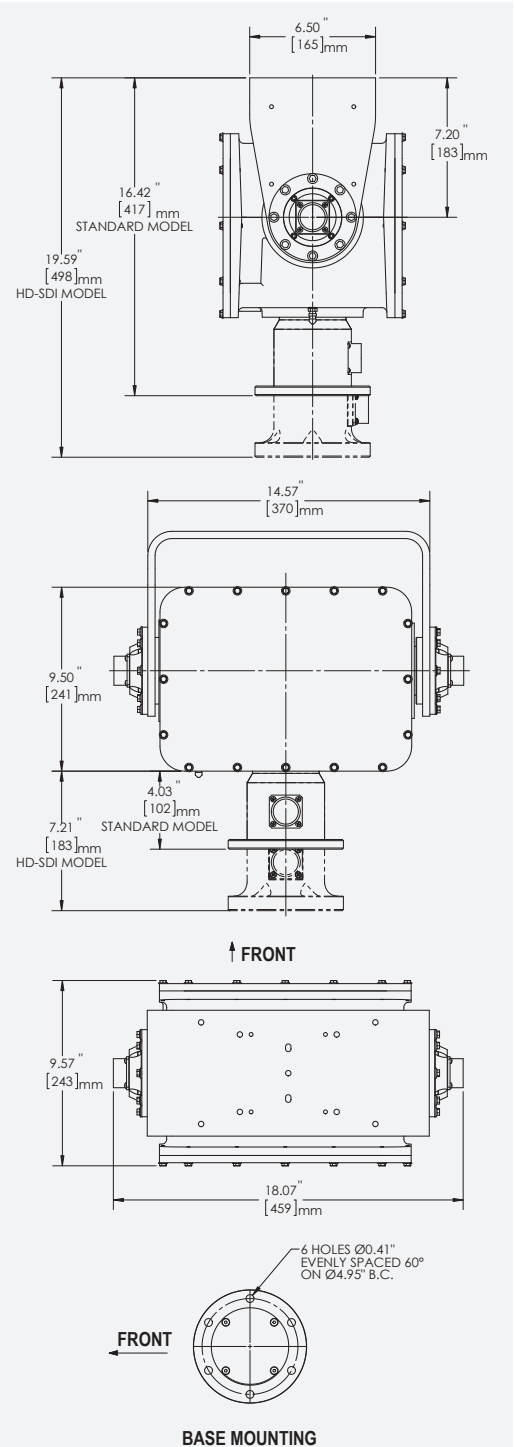

+1.847.498.0700 | www.quickset.com | sales@quickset.com



QuicksetDefenseTechnologies LLC



@QuicksetDefense



@QuicksetDefense



@QuicksetDefense

Equipment described herein falls under the jurisdiction of the EAR and may require US Government Authorization for export purposes. Diversion contrary to US law is prohibited.

© 2022 Quickset Defense Technologies, LLC. All rights reserved.  
Product and company names listed are trademarks or trade names of their respective companies.  
Specifications are subject to change, to confirm current call +1 847.498.0700.